



JLE33BUD1 -2

1-Line Bi-directional TVS Diode

Jialan-Microelectronics

Description

The JLE33BUD1 -2 is an Bi-directional TVS diode, utilizing leading monolithic silicon technology to provide fast response time and ultra low ESD clamping voltage, making this device an ideal solution for protecting voltage sensitive data and power line.

The JLE33BUD1 -2 complies with the IEC 61000-4-2 (ESD) with $\pm 30kV$ air and $\pm 28kV$ contact discharge. It is assembled into an ultra-small DFN0603 lead-free package. The small size and high ESD surge protection make JLE33BUD1 -2 an ideal choice to protect cell phone, digital cameras, audio players and many other portable applications.

Features

- * 30W peak pulse power (8/20 μ s)
- * Low leakage:nA level
- * Operating voltage: 3.3V
- * Low clamping voltage
- * One power line protects
- * Complies with following standards:
 - IEC 61000-4-2 (ESD) immunity test
 - Air discharge: $\pm 30kV$
 - Contact discharge: $\pm 28kV$
 - IEC61000-4-5 (Lightning) 3A (8/20 μ s)
- * RoHS Compliant
- * Package: DFN0603-2

Circuit Diagram

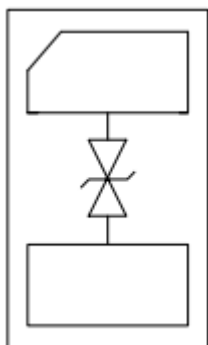

Circuit and Pin Schematic

Applications

- * Cellular Handsets and Accessories
- * Personal Digital Assistants
- * Notebooks and Handhelds
- * Portable Instrumentation
- * Digital Cameras
- * Peripherals
- * Audio Players
- * Keypads, Side Keys, LCD Displays

Marking Diagram

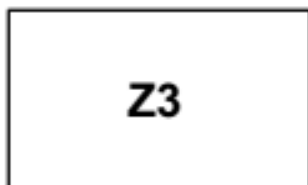

Transparent top view

Z3: Device Marking Code

Ordering Information

Part Number	Packaging	Reel Size
JLE33BUD1-2	3000/Tape & Reel	7 inch



JLE33BUD1-2

Absolute Maximum Ratings ($T_A=25^\circ\text{C}$ unless otherwise specified)

Parameter	Symbol	Value	Unit
Peak Pulse Power (8/20 μs)	Ppk	30	W
Peak Pulse Current (8/20 μs)	IPP	3	A
ESD per IEC 61000-4-2 (Air)	VESD	± 30	kV
ESD per IEC 61000-4-2 (Contact)		± 28	
Operating Temperature Range	TJ	-55to +125	$^\circ\text{C}$
Storage Temperature Range	Tstg	-55 to +150	$^\circ\text{C}$

Electrical Characteristics ($T_A=25^\circ\text{C}$ unless otherwise specified)

Parameter	Symbol	Test Condition	Min	Typ	Max	Unit
Reverse Working Voltage	V_{RWM}	Pin 1 to Pin 2 or Pin 2 to Pin 1			3.3	V
Breakdown Voltage	V_{BR}	$I_T = 1\text{mA}$, Pin 1 to Pin 2 or Pin 2 to Pin 1	4.3			V
Reverse Leakage Current	I_R	$V_{RWM} = 3.3\text{V}$, Pin 1 Pin 2 or Pin 1 to Pin 2			0.2	μA
Clamping Voltage	V_C	$I_{PP} = 3\text{A}$ (8 x 20 μs pulse), Pin 1 to Pin 2 or Pin to Pin 2			10	V
Junction Capacitance	C_J	$V_R = 0\text{V}$, $f = 1\text{MHz}$,)		3		pF

Portion Electronics Parameter

Symbol	Parameter
I_T	Test Current
I_{PP}	Maximum Reverse Peak Pulse Current
V_C	Clamping Voltage @ I_C

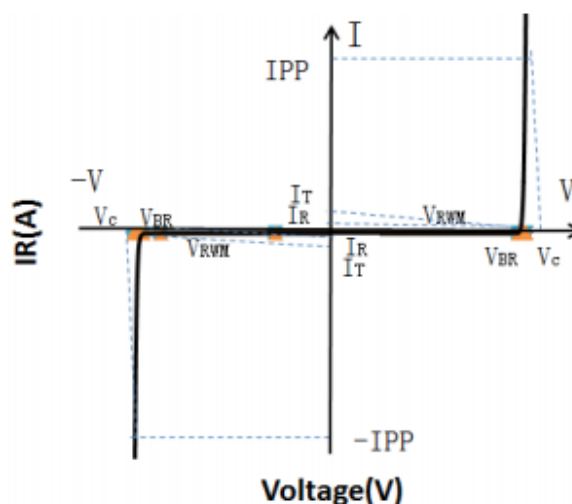



JLE33BUD1-2

Typical Performance Characteristics ($T_A=25^\circ\text{C}$ unless otherwise Specified)

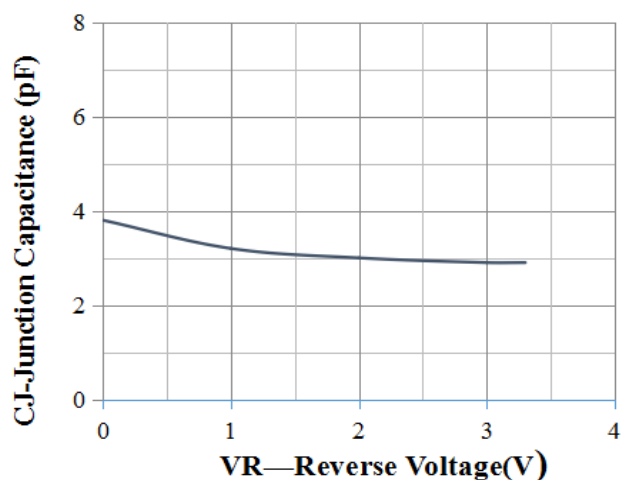

Junction Capacitance vs. Reverse Voltage

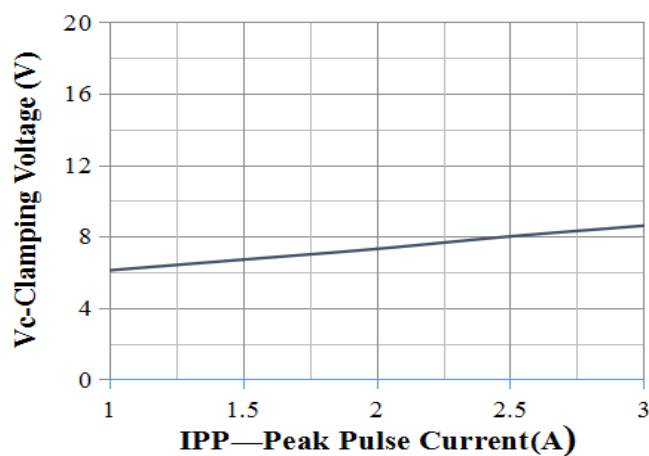

Clamping Voltage vs. Peak Pulse Current

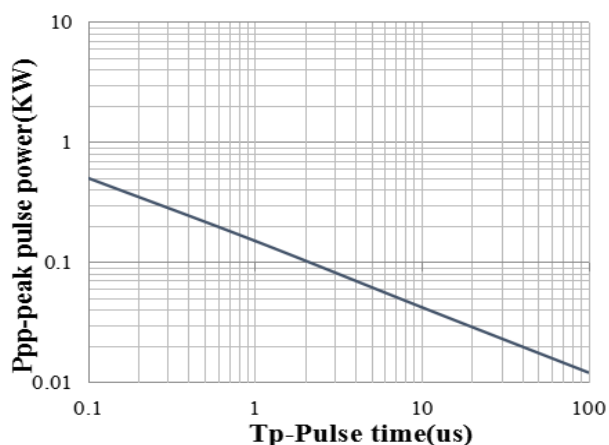

Peak Pulse Power vs. Pulse Time

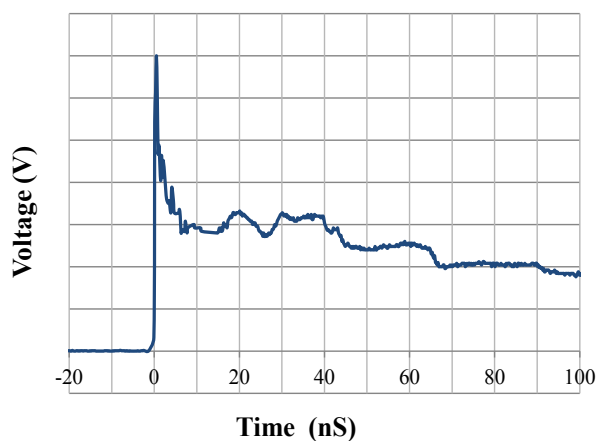

IEC61000-4-2 Pulse Waveform

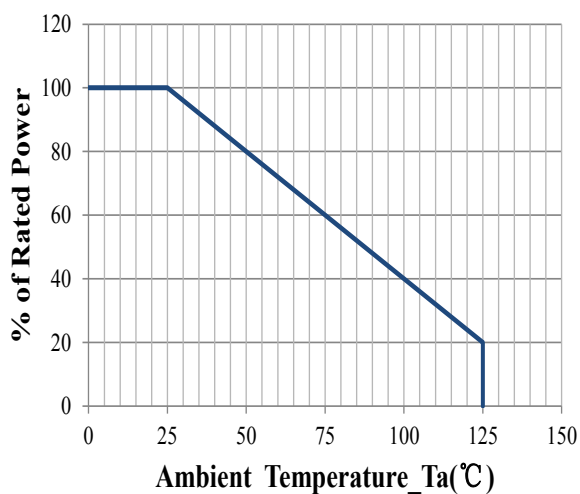

Power Derating Curve

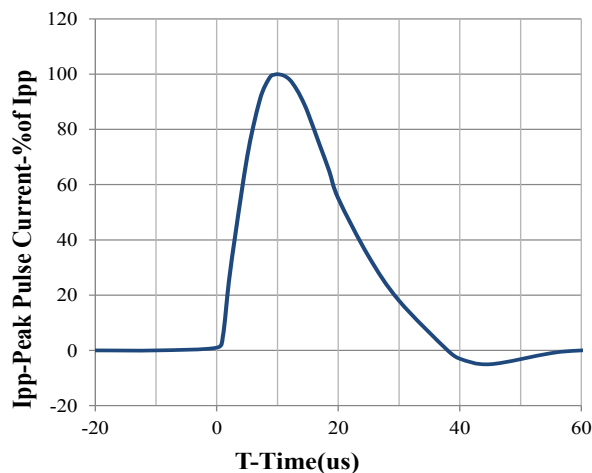

8 X 20us Pulse Waveform



JLE33BUD1-2

DFN0603-2 Package Outline Drawing (Dimensions in millimeters)

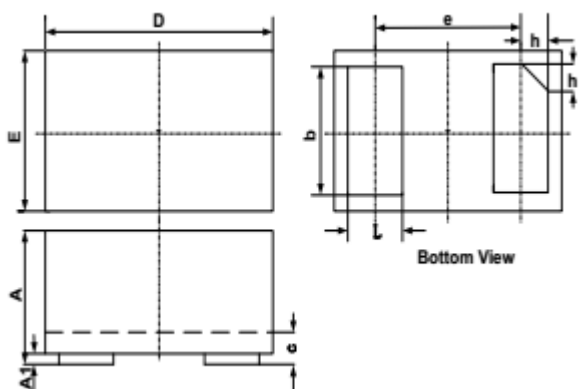

SYM	DIMENSIONS		
	MILLIMETERS		
	MIN	NOM	MAX
A	0.230		0.330
A1	0.000	0.020	0.050
b	0.215	0.245	0.275
c	0.120	0.150	0.180
D	0.550	0.600	0.650
e	0.355 BSC		
E	0.250	0.300	0.350
L	0.160	0.190	0.220
h	0.079 BSC		

Suggested Land Pattern

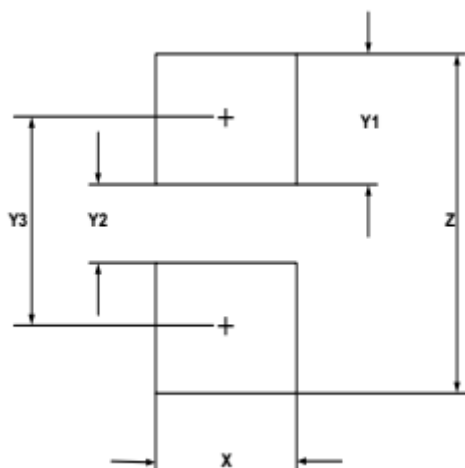

SYM	DIMENSIONS	
	MILLIMETERS	INCHES
X	0.30	0.012
Y1	0.25	0.010
Y2	0.15	0.006
Y3	0.40	0.016
Z	0.65	0.026

NOTICE

Jelan-Link reserves the right to make changes without further notice to any products here in.

Only obligations are those in the Jelan-Link Standard Terms and Conditions of Sale and in no case will Jelan-Link be liable for any incidental, indirect, or consequential damages arising from the sale, resale, use, or misuse of its products.